

Product catalogue



Load measurement and monitoring solutions



Specialists in load measurement and monitoring technology, Scotload is the supplier of choice for rigging, lifting and load testing operators worldwide.

Scotload is an expert in load measurement and monitoring solutions across many different industries including - oil and gas, marine, renewables and construction.

With decades of experience we can provide consultancy advice and project management services as well as high quality load monitoring products.

A part of James Fisher and Sons plc, we have a wealth of global resources available at our fingertips to support our customers. So whatever you need and wherever you need it, we will work with you to identify the best possible solution for your application.

Our reputation is built on quality products and services, engineered to the highest of standards.

- All Scotload products are designed and manufactured in the UK ensuring the highest standard of quality
- In-house expertise enables us to meet our customer's exacting requirements
- We are world leaders in supporting a vast range of complex load monitoring solutions
- Specialists in hazardous area applications
- We offer fast delivery ex-stock available for immediate distribution
- We provide a high standard of service with a single point of contact for all your project enquiries, from concept to delivery





Safety is our number one priority, all Scotload products are rigorously tested and inspected.

Safety and reliability are critical factors in the lifting industry and we operate to **ISO 9001:2008** accredited quality management system to ensure product excellence.

Our hazardous area products are fully certified by **SGS Baseefa** - the leading, internationally recognised certification body for explosion protected equipment, delivering **IECEX**, **ATEX** and **DSEAR** standards to customers around the world.

We are also members of **LEEA** - Lifting Equipment Engineers Association - the leading representative body for the lifting industry worldwide.



Scotload's calibration and repair service is available for both Scotload own and third party products.

We have unrivaled experience in calibrating load equipment and we also offer a popular in-house repair service.

We welcome third party products in addition to our own, and all equipment receives the same high standard of care.

All equipment is controlled under our quality management system. Our in-house testbeds are fully certified and are traceable to UKAS standards.

With in-house expertise and a wealth of resources available we provide a quick resolution for your technical issues.

Innovation | Excellence | Delivery

We have an enviable reputation for **technical innovation** and meeting challenging objectives through the delivery of creative and cost effective solutions.

We work with you to identify and implement innovative and achievable project outcomes to deliver improved operational performance.

Project management and bespoke offerings

Our highly skilled team of professionals have the expertise required to support your needs during all phases of your project. We offer in-house bespoke product design and manufacturing for specific client requirements and we can also provide a complete project management capability to manage delivery to time, quality and cost, while guaranteeing compliance to the highest of safety regulations.

Available for sale and hire

Scotload has a comprehensive stock of load measurement products available for sale and hire. This service is ideal for short and long-term loans of equipment without the need for large upfront purchase costs. We have a significant amount of ex-stock available for immediate distribution.

A revolution in load measurement

SmartLoad®

SmartLoad® is an innovative, intelligent load cell system that stores data for real time and retrospective analysis, providing asset owners with protection against potential misuse and overload events.

The benefits of

- Automated overload protection monitoring for **safety assurance**
- Uniquely **incorporates intelligence** on the load cell as well as the handset for real time and retrospective analysis
- Provides significantly **increased range** and signal reliability
- **Simple 'plug-and-play' system** you can use straight from the box - no training required
- Can be **integrated** with your existing monitoring systems
- System redundancy with **no handset pairing** required

Our innovative SmartLoad® technology can be retrofitted to your existing equipment, removing need for expensive full system upgrades.

Features of SmartLoad®:

- Simple and intuitive to use
- 'Scan and select' to connect to load cells
- On board intelligence and memory
- Overload protection
- Retrofit to existing load cells
- Latest wireless technology
- Automatic report generation



Improve your workplace safety, reduce downtime and lower costs with SmartLoad® - the innovative and award winning, intelligent load cell system.

The PC analysis software:

- Displays live readings for up to 128 cells
- Real time trace of the latest 100 readings
- Monitors peak readings from each device
- Instant display of overload events
- Downloads event logs (Excel compatible)
- Control cell transmission and logging frequencies
- Remotely controls cell logging
- Monitors battery life of remote cells
- Remotely upgrades cell and handset firmware
- Custom reports available
- Allows equipment calibration

The handset:

- Automatically detects all cells in range
- Live simultaneous display of multiple cells
- Displays the average and total readings
- Intuitive menu driven flexible display
- Start / stop logging from handset
- Peak reading and tare display
- Increased range and reduced interference
- Variable overload audio alarm
- Individual load cell naming facility

The load cell transmitter:

- Seamless retrofit to existing load cells
- Date and time stamp for all usage
- Peak readings recorded and logged
- Overload events recorded and logged
- Variable sample rates to suit application
- Low power for long battery life
- Calibration records held on transmitter
- On board intelligence

Includes SmartLoad® technology

Load links



Scotload's load links are ideal for all lifting and weighing applications where accurate and reliable load monitoring is required.

Manufactured from high tensile, aerospace grade anodised aluminium, our load links are suitable for use across all industry sectors including marine and offshore.

We have a range of links in stock available to purchase or hire, and ready for immediate dispatch. We also offer a custom design and manufacturing to suit any specific applications, as well as an in-house repair and calibration service.

Options

- Cabled and wireless versions
- Built in display options
- Hazardous area options
- IP67 or IP68 sealing
- Internal antenna for added protection
- Bespoke sizes manufactured on request
- Available ex-stock for purchase or hire
- Available with intelligent SmartLoad® technology

Benefits

- Designed and manufactured in the UK ensuring quality
- Long design life
- Highly accurate and reliable
- High safety factor
- Easy to install and operate
- Corrosion resistance
- 12 month warranty - longer warranty available on request

Typical specification mV/V output

Rated load	As required
Proof load	150% of rated load
Output signal	mV/V
Electrical connection	4 core
Cable connection	Gland or connector
Cable length	5m as standard
Recommended excitation voltage	10V
Maximum excitation voltage	15V
Bridge resistance	1000 Ohm
Sensitivity	1.5mV/V nominal
Non linearity	< ± 0.25% of full scale
Non repeatability	< ± 0.05% of full scale
Zero balance	< ± 0.05% of full scale
Environmental protection	IP67 / IP68
Safety factor	5x
Operating temperature range	-25°C to +70°C
Storage temperature range	-30°C to + 80°C

Typical specification mA output

Rated load	As required
Proof load	150% of rated load
Output signal	4-20mA
Electrical connection	2 or 3 wire
Cable connection	Gland or connector
Cable length	5m as standard
Recommended supply voltage	24V
Maximum supply voltage	30V
Non linearity	< ± 0.25% of full scale
Non repeatability	< ± 0.05% of full scale
Zero balance	< ± 0.05% of full scale
Environmental protection	IP67 / IP68
Safety factor	5x
Operating temperature range	-25°C to +70°C
Storage temperature range	-30°C to + 80°C

Typical specification wireless output

Rated load	As required
Proof load	150% of rated load
Output signal	Wireless telemetry
Data logging	On load cell
Battery type	2 x AA
Battery life (active)	Up to 200 hours
Battery life (standby)	Up to 1400 hours
Telemetry frequency	2.4Ghz ISM
System range	Up to 350m
Non linearity	< ± 0.25% of full scale
Non repeatability	< ± 0.05% of full scale
Zero balance	< ± 0.05% of full scale
Data rate	57600 bit/s
Environmental protection	IP67 / IP68
Safety factor	5x
Operating temperature range	-25°C to +70°C
Storage temperature range	-30°C to + 80°C

Cabled load link

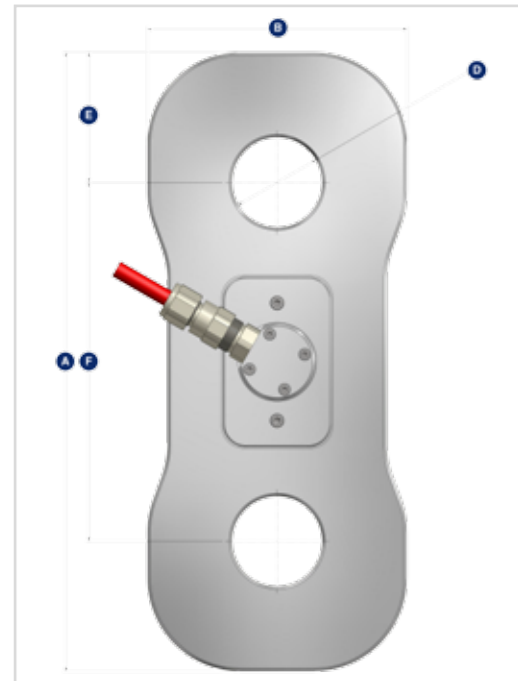

Wireless load link



Load links typical dimensions - bespoke design available on request

Product code (wireless)	TEN 9250	TEN 9251	TEN 9252	TEN 9253	TEN 9254	TEN 9255	TEN 9256	TEN 9257	TEN 9258	TEN 9259	TEN 9260	TEN 9261	TEN 9262	TEN 9263
Product code (cabled)	TEN 9627	TEN 9628	TEN 9629	TEN 9630	TEN 9631	TEN 9632	TEN 9633	TEN 9634	TEN 9635	TEN 9636	TEN 9637	TEN 9638	TEN 9639	TEN 9640
Load rating (tonnes)	2	5	12.5	25	35	50	75	120	150	200	250	300	400	500
Weight (kg)	1.3	1.8	3.5	7	10.8	17.3	29.5	56.5	78.9	122	158	203	304	408
A mm	230	250	300	350	400	450	480	590	660	780	830	920	1060	1150
B mm	74	84	108	144	168	202	244	294	324	400	440	498	584	636
C mm	24	32	50	65	75	90	110	141	161	170	189	189	213	237
D mm	20	26	40	52	58	71	84	97	110	133	143	153	178	188
E mm	37	37	54	72	84	101	122	147	162	200	220	249	292	318
F mm	156	176	192	206	232	248	236	296	336	380	390	422	476	514
G mm (wireless)	50	48	N/A	N/A	N/A	N/A	N/A	N/A	N/A	N/A	N/A	N/A	N/A	N/A
G mm (cabled)	81	79	81	96	106	121	141	172	192	201	220	220	244	268

All our load links are supplied with a proof load certificate, calibration certificate and robust carry case.

Includes SmartLoad® technology

Load shackles



Scotload's load shackles are ideal for compact and reliable, lifting and weighing applications across all industry sectors including marine, offshore and subsea.

Our load shackles include an innovative load bobbin design with a robust anti-rotation bracket to ensure the load is centralised.

We have a large range of ex-stock shackles available to purchase or hire, ready for immediate dispatch. We also offer a custom design and manufacturing service to suit any specific requests, as well as an in-house repair and calibration service.

Options

- Cabled and wireless versions
- Available for subsea applications
- Hazardous area options
- IP67 or IP68 sealing
- Internal antenna for added protection
- Bespoke sizes manufactured on request
- Available ex-stock for purchase or hire
- Available with intelligent SmartLoad® technology

Benefits

- Designed and manufactured in the UK ensuring quality
- Custom design available
- Highly accurate and reliable
- Easy to install and operate
- Ideal for applications with limited headroom
- 12 month warranty - longer warranty available on request

Typical specification mV/V output

Rated load	As required
Proof load	150% of rated load
Output signal	mV/V
Electrical connection	4 core
Cable connection	Gland or connector
Cable length	5m as standard
Recommended excitation voltage	10V
Maximum excitation voltage	15V
Bridge resistance	700 Ohm
Sensitivity	2.0mV/V nominal
Non linearity	< ± 1% of full scale
Non repeatability	< ± 0.01% of full scale
Zero balance	< ± 0.01% of full scale
Environmental protection	IP68
Safety factor	3x
Operating temperature range	-25°C to +70°C
Storage temperature range	-30°C to + 80°C

Typical specification mA output

Rated load	As required
Proof load	150% of rated load
Output signal	4-20mA
Electrical connection	2 or 3 wire
Cable connection	Gland or connector
Cable length	5m as standard
Recommended supply voltage	24V
Maximum supply voltage	30V
Non linearity	< ± 1% of full scale
Non repeatability	< ± 0.01% of full scale
Zero balance	< ± 0.01% of full scale
Environmental protection	IP68
Safety factor	3x
Operating temperature range	-25°C to +70°C
Storage temperature range	-30°C to + 80°C

Typical specification wireless output

Rated load	As required
Proof load	150% of rated load
Output signal	Wireless telemetry
Data logging	On load cell
Battery type	4 x AA
Battery life (active)	Up to 350 hours
Battery life (standby)	Up to 1700 hours
Telemetry frequency	2.4Ghz ISM
System range	Up to 350m
Non linearity	< ± 1% of full scale
Non repeatability	< ± 0.01% of full scale
Zero balance	< ± 0.01% of full scale
Data rate	57600 bit/s
Environmental protection	IP67 / IP68
Safety factor	3x
Operating temperature range	-25°C to +70°C
Storage temperature range	-30°C to + 80°C

Cabled load shackle

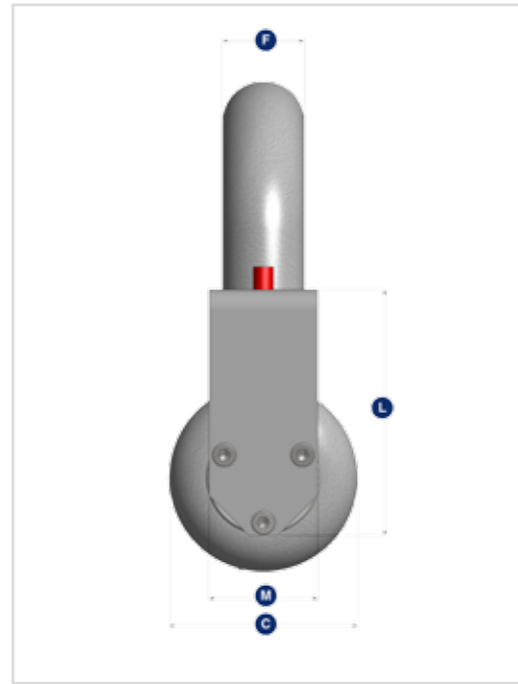
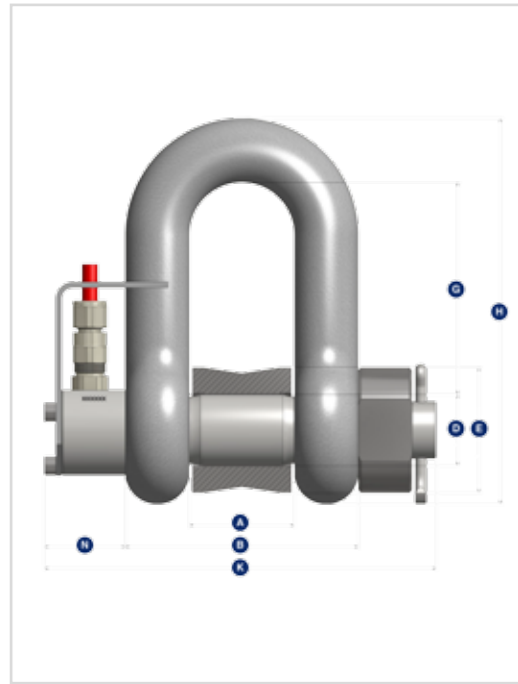

Wireless load shackle

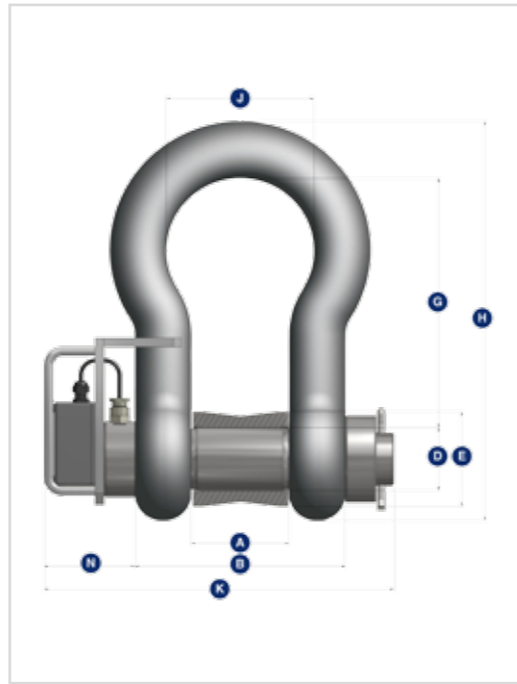

All our load shackles are supplied with a proof load certificate and calibration certificate.

Load shackles typical dimensions - bespoke design available on request

Load rating (tonnes)	8.5	12	17	25	35	55	85	120	150	200	300	400	500	600	700	800	900	1000
Approx weight bow (kg)	2.6	4.9	8.2	14.2	19.9	39.6	62	110	160	235	340	560	685	880	980	1100	1280	1460
Approx weight dee (kg)	2.5	4.5	7.6	12.9	17.4	35.3	53	N/A	N/A	N/A	N/A	N/A	N/A	N/A	N/A	N/A	N/A	N/A
A mm	43	51	60	74	83	105	127	150	170	180	205	230	255	285	310	310	330	350
B mm	93	115	136	164	183	235	273	328	374	420	465	560	615	675	720	730	770	810
C mm	59	72	88	103	111	145	162	200	230	260	305	350	570	405	435	435	465	480
D mm	28	35	42	50	57	70	83	95	108	140	150	175	185	205	217	217	230	240
E mm	44	50	63	88	88	114	125	152	165	190	254	254	300	300	330	330	355	355
F mm	25	32	38	45	50	65	75	89	102	120	130	165	180	195	205	210	220	230
G mm (bow)	95	115	146	178	197	260	329	380	400	500	600	680	700	700	700	700	700	750
G mm (dee)	85	94	127	149	171	203	339	N/A	N/A	N/A	N/A	N/A	N/A	N/A	N/A	N/A	N/A	N/A
H mm (bow)	164	201	249	300	331	433	527	617	671	813	958	1108	1158	1200	1231	1236	1268	1290
H mm (dee)	154	180	230	271	305	376	427	N/A	N/A	N/A	N/A	N/A	N/A	N/A	N/A	N/A	N/A	N/A
J mm (bow only)	68	83	99	126	138	180	190	238	275	290	305	325	350	375	400	400	420	420
K mm (wireless)	224	274	304	338	361	410	454	482	535	615	665	762	817	912	957	967	1011	1020
K mm (cabled)	159	209	242	276	297	347	391	440	493	550	600	695	750	845	890	900	944	953
L mm (wireless)	200	200	200	200	200	210	220	N/A	N/A	176	203	N/A	N/A	N/A	N/A	N/A	N/A	N/A
L mm (cabled)	110	119	131	136	160	180	205	N/A	N/A	N/A	N/A	N/A	N/A	N/A	N/A	N/A	N/A	N/A
M mm (wireless)	100	100	100	100	100	110	120	N/A	N/A	80	100	N/A	N/A	N/A	N/A	N/A	N/A	N/A
M mm (cabled)	50	50	50	60	75	88	100	N/A	N/A	N/A	N/A	N/A	N/A	N/A	N/A	N/A	N/A	N/A
N mm (wireless)	119	119	119	119	121	118	118	92	92	115	115	117	122	127	127	127	127	127
N mm (cabled)	54	55	57	57	57	55	55	50	50	50	50	50	55	60	60	60	60	60

Includes SmartLoad® technology

Running line monitor



Scotload's running line monitors' rugged design makes them ideal for operation in the most extreme environments, including both offshore and onshore applications.

Constructed with stainless steel, incorporating a marinised finish to prevent corrosion, our running line monitors have been designed to suit various rope sizes and capacities depending on your needs.

We have a range of stock available to buy or hire, ready for immediate dispatch. We also offer a custom design and manufacturing service to suit any specific requirements, as well as an in-house repair and calibration service.

Options

- Cabled and wireless versions
- Hazardous area options
- Optional built in display
- Mains or battery powered indicators
- Three or five roller option
- Bespoke sizes manufactured on request
- Available ex-stock for purchase or hire
- Available with intelligent SmartLoad® technology

Benefits

- Designed and manufactured in the UK ensuring quality
- Custom design available
- Robust construction for use in hostile environments
- Easy to install and operate
- Highly accurate and reliable
- 12 month warranty - longer warranty available on request

Typical specification mA output

Rated load	As required
Proof load	200% of rated load (dependent on rope capacity)
Rope diameter	10mm to 125mm
Output signal	4-20mA (load) Pulsed output, quadrature mode (distance/speed)
Electrical connection	8 core (load and distance/ speed)
Cable connection	Gland and connector
Cable length	5m as standard
Recommended supply voltage	24V
Maximum supply voltage	30V
Non linearity	< ± 1% of full scale
Non repeatability	< ± 0.01% of full scale
Zero balance	< ± 0.01% of full scale
Environmental protection	IP66
Operating temperature range	-20°C to +60°C
Storage temperature range	-30°C to +80°C

Typical specification wireless output

Rated load	As required
Proof load	200% of rated load (dependent on rope capacity)
Rope diameter	10mm to 125mm
Output signal	Wireless telemetry
Data logging	On load cell
Battery type	3 x D
Battery life (active)	Up to 350 hours
Battery life (standby)	Up to 1700 hours
Telemetry frequency	2.4GHz ISM
System range	Up to 350m
Non linearity	< ± 1% of full scale
Non repeatability	< ± 0.01% of full scale
Zero balance	< ± 0.01% of full scale
Data rate	57600 bit/s
Environmental protection	IP66
Operating temperature range	-20°C to +60°C
Storage temperature range	-30°C to +80°C



Ex-stock available now for immediate dispatch!

Cabled running line monitor

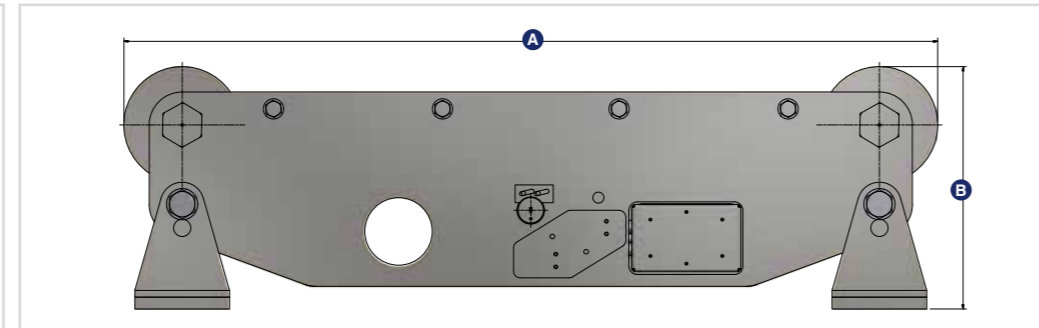
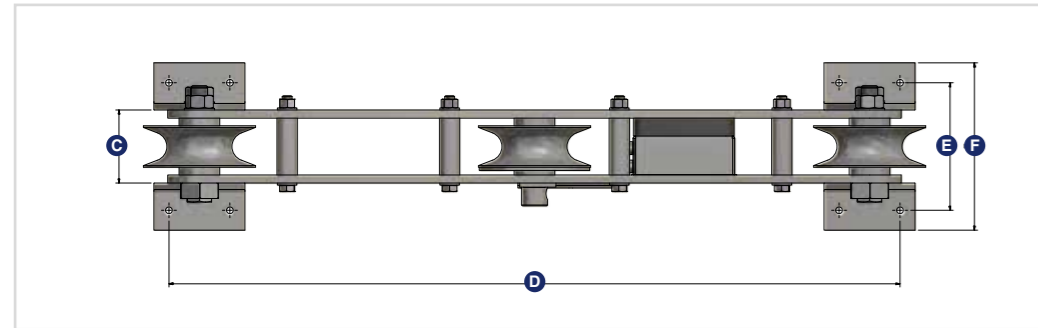

Wireless running line monitor

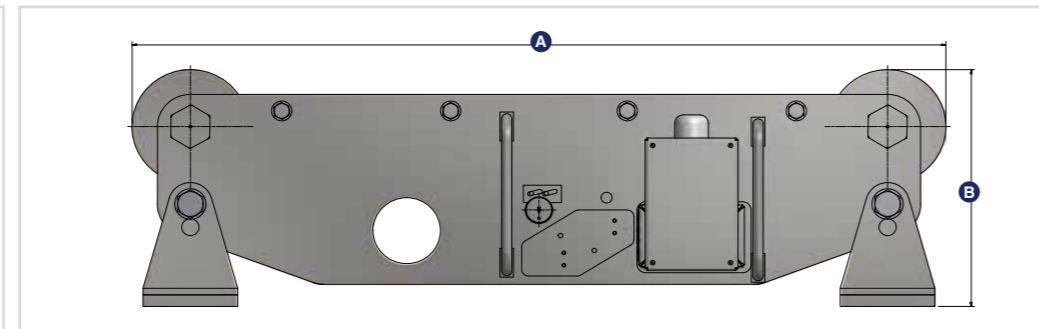
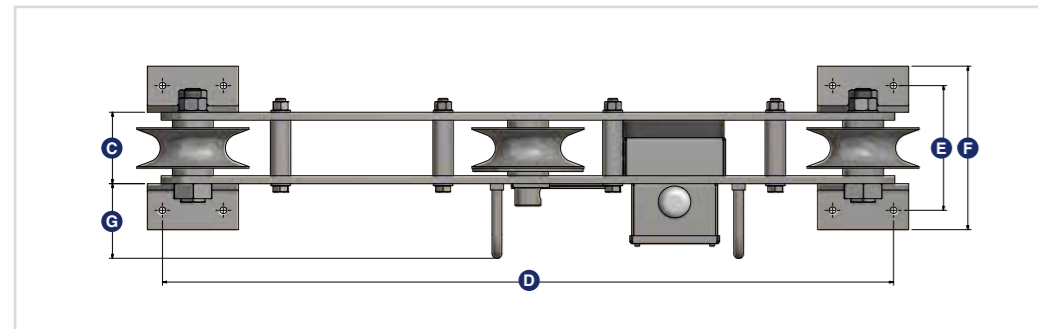

Running line monitor typical dimensions - bespoke design available on request

Model type	Model 1	Model 2	Model 3	Model 4
Sheave sizes available (mm)	10 - 25	22 - 28	32 - 40	42 - 48
A mm	722	810	963	1028
B mm	250	270	297	331
C mm	62	90	90	95
D mm	601	785	899	936
E mm	112	146	148	153
F mm	162	186	188	193
G mm (wireless only)	95	95	95	95

All our RLM's are ideal for measuring load, distance and speed of all types of wires.

Includes SmartLoad® technology

Static line monitor

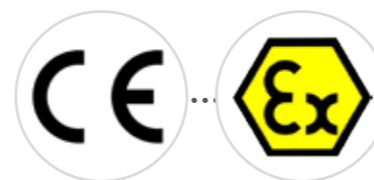

Scotload's static line monitors are ideal for hostile marine and offshore industries where a fixed means of measurement is impractical.

Manufactured from high tensile aluminium or stainless steel, our static line monitors can be customised to suit various rope sizes. They provide highly accurate readings to ensure that load remains within safe working limits.

We have a range of stock available to buy or hire, and ready for immediate dispatch. We also offer a custom design and manufacturing service to suit any specialised requests, as well as an in-house repair and calibration service.

Options

- Cabled and wireless versions
- Hazardous area options
- Mains or battery powered indicators
- Aluminium or stainless steel
- Subcon assembly
- Bespoke sizes manufactured on request
- Available ex-stock for purchase or hire
- Available with intelligent SmartLoad® technology

Benefits

- Designed and manufactured in the UK ensuring quality
- Custom design available
- Robust construction for use in hostile environments
- Easy to transport, install and operate
- Highly accurate and reliable
- 12 month warranty - longer warranty available on request

Static line monitor

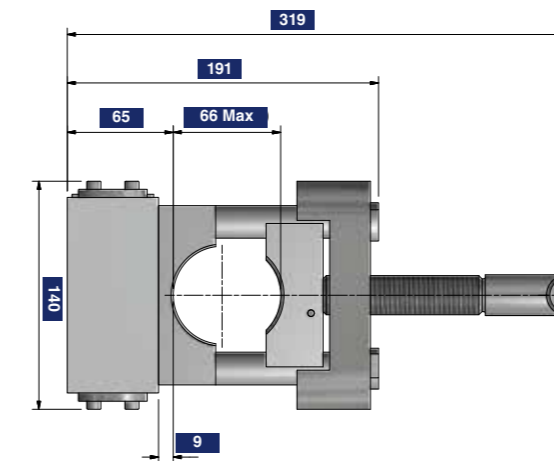
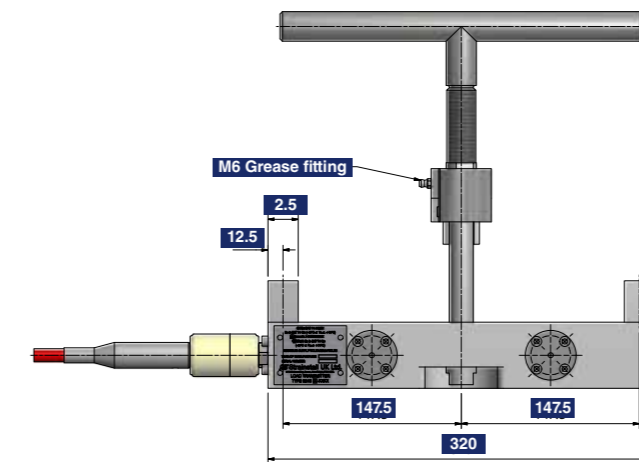

Typical specification mA output

Rated load	As required
Proof load	200% of rated load (dependent on rope capacity)
Rope diameter	22mm to 50mm
Output signal	4-20mA
Electrical connection	2 or 3 wire
Cable connection	Gland and connector
Cable length	5m as standard
Recommended supply voltage	24V
Maximum supply voltage	30V
Environmental protection	IP67
Operating temperature range	-20°C to +60°C
Storage temperature range	-30°C to +80°C

Includes SmartLoad® technology

Load pins



Scotload's load pins are suitable for use across a range of markets including heavy industry, offshore, marine, rail, aerospace and weighing.

Manufactured from high tensile stainless steel, our load pins are suitable for hazardous area and subsea applications, and they can be easily retrofitted with no disruption to existing systems.

We have a range of stock available to buy, and ready for immediate dispatch. We also offer a custom design and manufacturing service to suit any specialised requests, as well as an in-house repair and calibration service.

Options

- Cabled and wireless versions
- Available for subsea applications
- Hazardous area options
- IP67 or IP68 sealing
- Bespoke sizes manufactured on request
- Available with intelligent SmartLoad® technology

Benefits

- Designed and manufactured in the UK ensuring quality
- Custom design available
- High safety factor
- Can be retrofitted
- Easy to install and operate
- Highly accurate and reliable
- 12 month warranty - longer warranty available on request

Typical specification mV/V output

Rated load	As required
Proof load	150% of rated load
Output signal	mV/V
Electrical connection	4 core
Cable connection	Gland or connector
Cable length	5m as standard
Recommended excitation voltage	10V
Maximum excitation voltage	15V
Bridge Resistance	700 Ohm
Sensitivity	1.0mV/V to 2.0mV/V nominal
Non linearity	< ± 1% of full scale
Non repeatability	< ± 0.1% of full scale
Zero balance	< ± 0.1% of full scale
Environmental protection	IP68
Safety factor	As required
Operating temperature range	-25°C to +70°C
Storage temperature range	-30°C to +80°C

Typical specification mA output

Rated load	As required
Proof load	150% of rated load
Output signal	4-20mA
Electrical connection	2 or 3 wire
Cable connection	Gland or connector
Cable length	5m as standard
Recommended supply voltage	24V
Maximum supply voltage	30V
Non linearity	< ± 1% of full scale
Non repeatability	< ± 0.1% of full scale
Zero balance	< ± 0.1% of full scale
Environmental protection	IP68
Safety factor	As required
Operating temperature range	-25°C to +70°C
Storage temperature range	-30°C to +80°C

Typical specification wireless output

Rated load	As required
Proof load	150% of rated load
Output signal	Wireless telemetry
Data logging	On load cell
Battery type	2 or 4 x AA
Battery life (active)	Up to 350 hours
Battery life (standby)	Up to 1700 hours
Telemetry frequency	2.4GHz ISM
System range	Up to 350m
Non linearity	< ± 1% of full scale
Non repeatability	< ± 0.1% of full scale
Zero balance	< ± 0.1% of full scale
Data rate	57600 bit/s
Environmental protection	IP67 / IP68
Safety factor	As required
Operating temperature range	-25°C to +70°C
Storage temperature range	-30°C to +80°C

Load pin

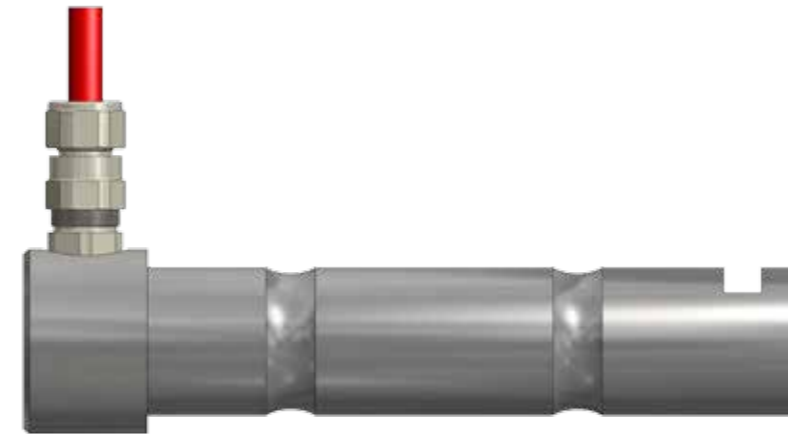

Our load pins can be customised and are supplied with a proof load certificate and calibration certificate.

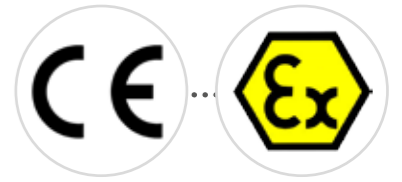
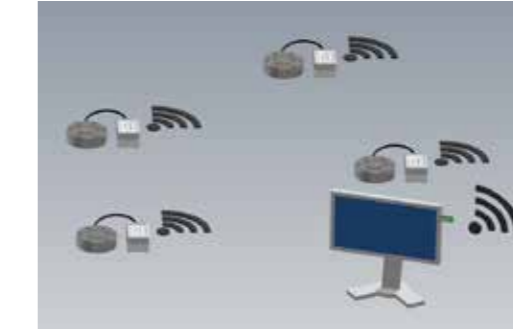
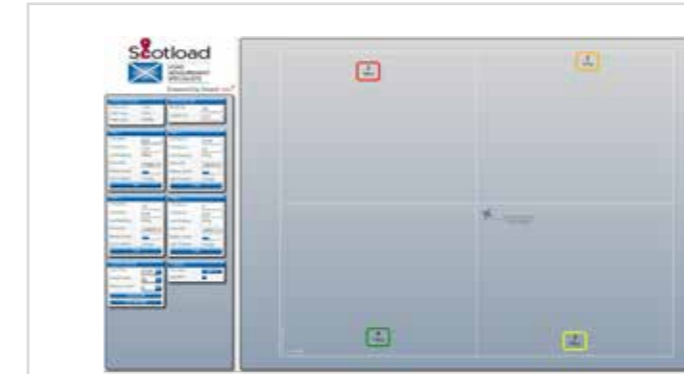

Scotload's centre of gravity (COG) system facilitates the safe lifting and transportation of structures and loads, such as offshore oil rigs, jack up rigs and vessels.

Integrating our award winning SmartLoad® technology, the system comprises load cells which weigh and conveniently calculates the centre of gravity, and our custom designed COG software which interprets and displays individual load cell readings, total loads and the centre of gravity.

Options

- Cabled and wireless versions
- Hazardous area options
- Available for purchase or hire
- Available with intelligent SmartLoad® technology

Benefits

- Designed and manufactured in the UK ensuring quality
- Highly accurate and reliable
- Facilitates safe lifting and transportation
- Weighs and calculates centre of gravity
- Wireless removes the need for cables improving safety
- 12 month warranty - longer warranty available on request

Includes SmartLoad® technology

Diaphragm load cells

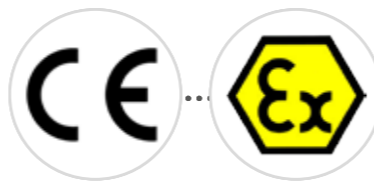
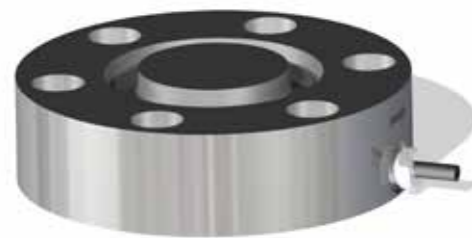

Scotload's diaphragm load cells are ideal for a range of structural and industrial applications where height may be limited and high accuracy is important.

Manufactured from high tensile stainless steel, our diaphragm load cells have a low profile and a high resistance to offset loads.

The standard fixing arrangement includes six counter bored holes with an optional base plate, which allows the load cells to become an integral part of the structures they are monitoring. They can also be supplied with tapped holes for more specialised installations.

Options

- Cabled and wireless versions
- Centrally bored or tapped holes
- Can be used singularly or in sets
- Base plate optional
- Bespoke sizes manufactured on request
- Available with intelligent SmartLoad® technology

Benefits

- Designed and manufactured in the UK ensuring quality
- Custom design available
- Can be retrofitted
- Easy to install and operate
- High safety factor
- Highly accurate and reliable
- 12 month warranty - longer warranty available on request

Typical specification mV/V output

Rated load	As required
Proof load	150% of rated load
Output signal	mV/V
Electrical connection	4 core
Cable connection	Gland or connector
Cable length	5m as standard
Recommended excitation voltage	10V
Maximum excitation voltage	15V
Bridge resistance	700 Ohm
Sensitivity	1.5mV/V - 2.0mV/V nominal
Non linearity	< ± 0.25% of full scale
Non repeatability	< ± 0.05% of full scale
Zero balance	< ± 0.05% of full scale
Environmental protection	IP68
Safety factor	As required
Operating temperature range	-20°C to +60°C
Storage temperature range	-30°C to +80°C

Typical specification mA output

Rated load	As required
Proof load	150% of rated load
Output signal	4-20mA
Electrical connection	2 or 3 wire
Cable connection	Gland or connector
Cable length	5m as standard
Recommended supply voltage	24V
Maximum supply voltage	30V
Non linearity	< ± 0.25% of full scale
Non repeatability	< ± 0.05% of full scale
Zero balance	< ± 0.05% of full scale
Environmental protection	IP68
Safety factor	As required
Operating temperature range	-20°C to +60°C
Storage temperature range	-30°C to +80°C

Our diaphragm load cells are ideal for centre of gravity, silo systems and structural weighing.

Diaphragm load cell



Diaphragm load cell typical dimensions

Product code	DIA 2800	DIA 3356	DIA 3357
Load rating (tonnes)	0.1 to 20	10 to 50	40 to 100
A mm	112	150	184
B mm	25	45	53
C mm	11	12	12
D mm	50	60	70
Hole H	To suit 6 x M6 SKT CAP screws on 98 P.C.D	To suit 6 x M12 SKT CAP screws on 122 P.C.D	To suit 6 x M16 SKT CAP screws on 146 P.C.D

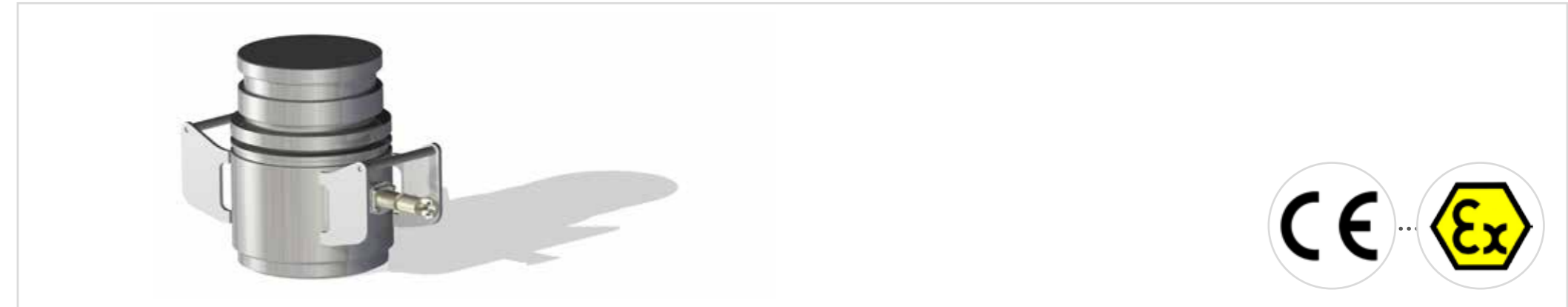

Scotload's range of compression load cells are adaptable to a large number of applications, including harsh environments.

Each load cell is fitted with a domed loading cap to greatly reduce the effect of offset loads. The load cells cable is fitted via an integral connector to allow for on site mating. This removes the need for handling large lengths of heavy duty cable whilst positioning the load cells.

We have a range of stock available to buy or hire, and ready for immediate dispatch. We also offer a custom design and manufacturing service to suit any specialised requests, as well as an in-house repair and calibration service.

Options

- Cabled and wireless versions
- Bespoke sizes manufactured on request
- Available with intelligent SmartLoad® technology

Benefits

- Designed and manufactured in the UK ensuring quality
- Custom design available
- Long design life
- Robust construction for use in hostile environments
- Easy to install and operate
- Improves operation safety
- Highly accurate and reliable
- 12 month warranty - longer warranty available on request

Typical specification mV/V output

Rated load	As required
Proof load	150% of rated load
Output signal	mV/V
Electrical connection	4 core
Cable connection	Gland or connector
Cable length	5m as standard
Recommended excitation voltage	10V
Maximum excitation voltage	15V
Bridge resistance	700 Ohm
Sensitivity	1.5mV/V - 2.0mV/V nominal
Non linearity	< ± 0.15% of full scale
Non repeatability	< ± 0.05% of full scale
Zero balance	< ± 0.05% of full scale
Environmental protection	As required
Safety factor	As required
Operating temperature range	-20°C to +60°C
Storage temperature range	-30°C to +80°C

Typical specification mA output

Rated load	As required
Proof load	150% of rated load
Output signal	4-20mA
Electrical connection	2 or 3 wire
Cable connection	Gland or connector
Cable length	5m as standard
Recommended supply voltage	24V
Maximum supply voltage	30V
Non linearity	< ± 0.15% of full scale
Non repeatability	< ± 0.05% of full scale
Zero balance	< ± 0.05% of full scale
Environmental protection	As required
Safety factor	As required
Operating temperature range	-20°C to +60°C
Storage temperature range	-30°C to +80°C

Compression load cell

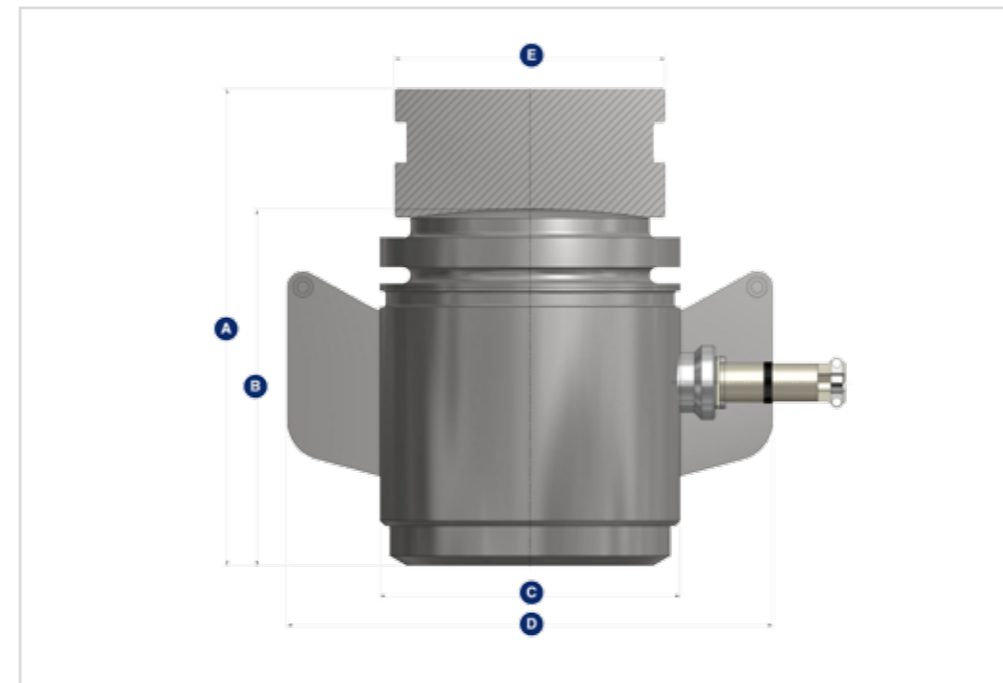

Compression load cell typical dimensions

Load rating (tonnes)	100	200	300	500	700	1000
Weight (kg)	8.5	18	28	75	86	160
A mm	170	215	240	320	350	400
B mm	127	163	179	248	281	315
C mm	100	126	151	216	216	272
D mm	184	210	244	320	320	246
E mm	86	112	136	196	196	246

Our compression load cells are ideal for centre of gravity, silo systems and structural weighing.

Scotload are specialists in load measurement products suitable for use in hazardous areas.

Standard and bespoke product solutions are available for all hazardous area load monitoring applications. We have cabled and wireless options available for both purchase or hire.

SmartLoad® wireless technology

Incorporating our intelligent load monitoring technology, SmartLoad 2Ex® and 1Ex® enables asset owners to identify and protect against overload events, by remotely examining load weight and calibration data in real time or retrospectively as required.

SmartLoad® eliminates the need for cabling in demanding work environments, improving safety as well as reducing costs associated with downtime due to cable damage and repair.



Scotload provides a comprehensive stress monitoring service, delivering fast, accurate and reliable data for a range of structures, equipment and components.

Using the most up-to date technology we offer a higher frequency of sampling to ensure all critical readings are captured at the crucial moments.

Our engineers will conduct a dynamic test program and our flexible approach facilitates any additional testing or changes as and when required.

Post processing of the data is conducted at Scotload and a full report will be available within 24 hours. Raw data is accessible after each test for urgent analysis if required.

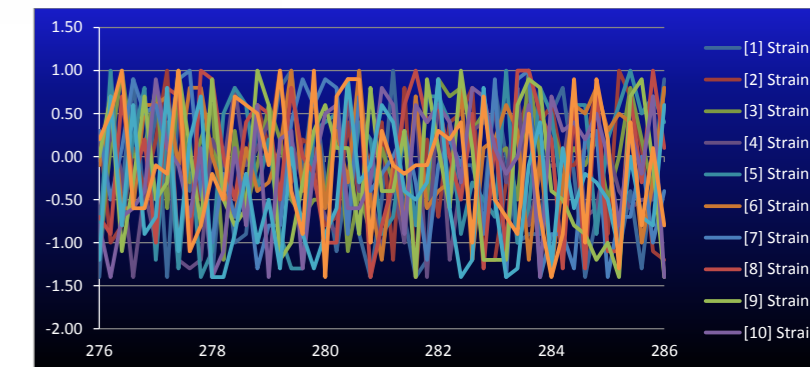
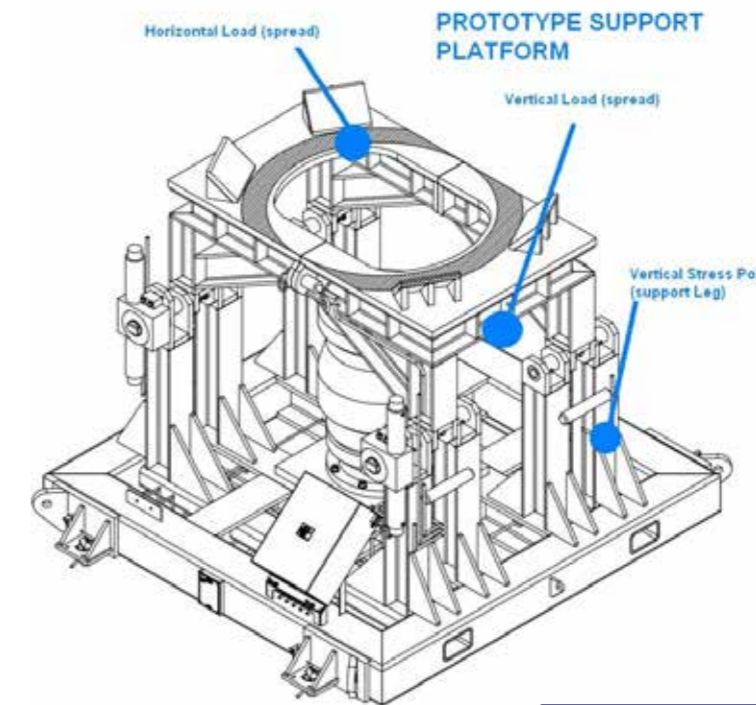

Scotload logging software has been exclusively designed and shaped to the needs of modern day load testing requirements

Using our intelligent SmartLoad® technology, users can run the program, select a test mode and begin recording without any complicated set up issues. Results are automatically exported into Excel and intelligence is displayed in an easy to understand format for immediate sharing

Key benefits of SmartLoad® logging capabilities:

- Automatically detects all cells in range – no pairing required
- Displays live readings of up to 128 cells simultaneously
- Provides a real-time trace, giving an overview of the last 100 readings to enable observation of trends at a glance
- Monitors peak readings from each device
- Shows instantly if a device has been overloaded
- Allows downloading of event logs and logged reading data from cells (Excel-compatible)
- Enables control of cell operating speeds and overload limits
- Remotely controls cell logging
- Monitors battery life of remote cells, avoiding downtime and unnecessary wastage
- Remotely upgrades cell and handset firmware as updates become available

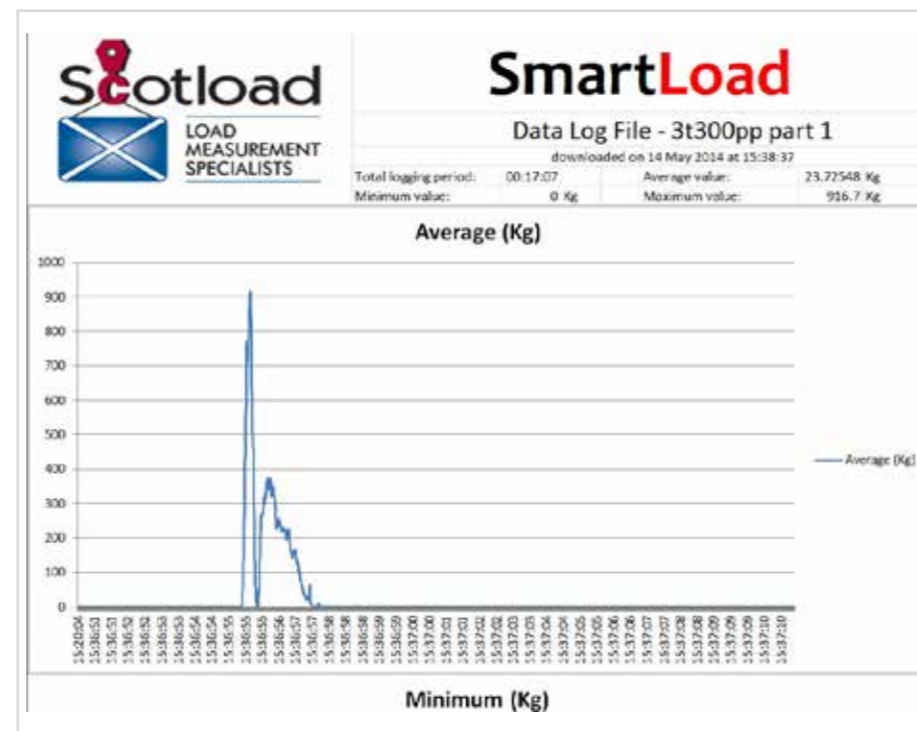

SmartLoad® software options:	Viewer	Logging	Calibration	Asset management
Description	Entry level version enables PC to be used like a handset and enable firmware upgrades.	Adds all logging functionality to the viewer version, can view multiple cells at once.	For users who want to be able to calibrate their own equipment	Includes all functionality designed for fleet management.
View one cell at a time	X		X	
View unlimited cells		X		X
Reset overload safety warning alarm			X	X
Set safety overload limit			X	X
View calibration certificate number	X	X	X	X
Update firmware	X	X	X	X
Calibrate load cells			X	X
Power cells up / down load cells wirelessly	X	X	X	X
Select from predefined speed profiles for logging		X		X
Adjust all logging speed parameters independently		Separate option		X
Start / stop logging		X		X
View / download log files		X		X
Log chart customisation service available with customer logo and branding (extra charge applies)		X	X	X
View / download event log		X		X
Delete and reset event log				X
Set user alarm limit and reset	X	X	X	X
Rename cells	X	X	X	X
View / reset peak reading	X	X	X	

Scotload has a wide range of indicators and handsets to match both high performance and budget requirements.

From standard battery powered hand-held to wireless units, main powered indicators and hazardous area approved displays, Scotload has a solution to meet any load measurement application.

Intuitive SmartLoad® displays

Our innovative and award winning SmartLoad® handsets have an intuitive, menu driven flexible display that can be used straight from the box.

Key benefits of SmartLoad® displays:

- Live simultaneous display of multiple cells
- Displays average and total readings
- Intuitive menu driven flexible display
- Start/stop logging from handset
- Scans automatically for local cells - no pairing required
- Peak reading and tare display
- Cabled and wireless options available
- Increased range and reduced interference
- Variable overload audio alarm
- Individual load cell naming facility



Experts in load measurement and monitoring across many industries worldwide, Scotload delivers innovative, bespoke and cost effective solutions to improve your operational performance.

Register for our mailing list to stay up-to-date with Scotload's latest product developments and exciting special offers!

Due to continuous development, Scotload reserves the right to change specifications without notice.

欢迎垂询：

电话：010-6556-2774 或 134-3966-9207

电邮：pauilyan@truslandoffshore.com